

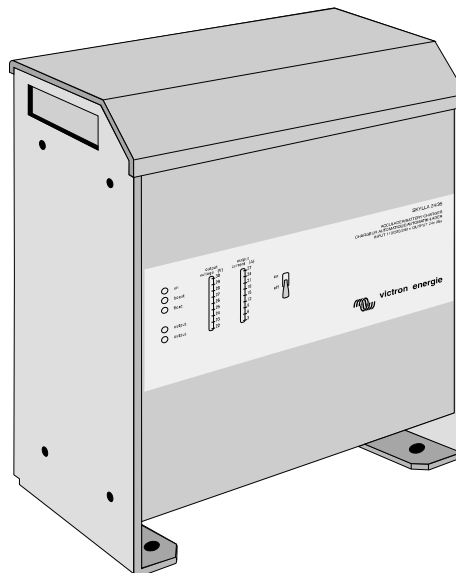

**USER MANUAL**  
**GEBRUIKSAANWIJZING**  
**GEBRAUCHSANWEISUNG**

**Victron Skylla 24/25**  
**Victron Skylla 24/50**  
**Victron Skylla 24/75**  
**Victron Skylla 24/100**



Color profile: Disabled  
Composite Default screen

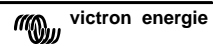

sk02001e.chp  
Fri Jan 26 11:54:28 1996

## **SECTIONS**

---

<b>ENGLISH</b>	<b>1</b>
<b>NEDERLANDS</b>	<b>41</b>
<b>DEUTSCH</b>	<b>81</b>

This page intentionally left blank.

## ENGLISH

### USER MANUAL

**Victron Skylla 24/25**  
**Victron Skylla 24/50**  
**Victron Skylla 24/75**  
**Victron Skylla 24/100**

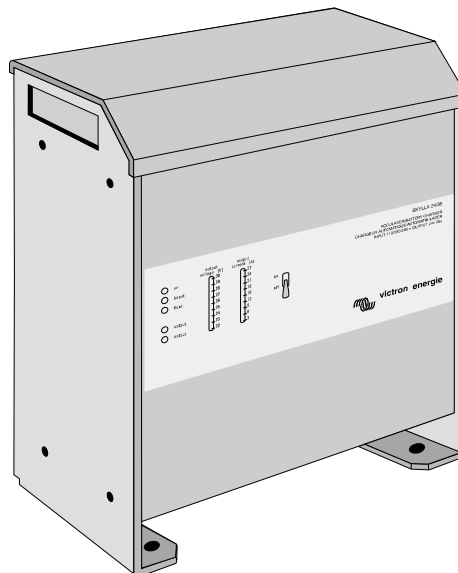

This page intentionally left blank.

## INTRODUCTION

---



Victron Energie has established an international reputation as a leading designer and manufacturer of power systems. Our R&D department is the driving force behind this reputation. It is continually seeking new ways of incorporating the latest technology in our products. Each step forward results in value-adding technical and economical features.

Our proven philosophy has resulted in a full range of state-of-the-art equipment for the supply of electrical power. All our equipment meets the most stringent requirements.

Victron Energie systems provide you with high-quality supplies at places where there are no permanent sources of mains power.

An automatic stand-alone power system can be created with a configuration comprising a Victron Energie inverter, battery charger, mains manager (if required) and, last but not least, batteries with sufficient capacity.

Our equipment is suitable for countless situations in the field, on ships or other places where a mobile 230-Volt<sub>ac</sub> power supply is indispensable.

Victron Energie has the ideal power source for all kinds of electrical appliances used for household, technical and administrative purposes, including instruments susceptible to interference. All of these applications require a high-quality power supply in order to function properly.

### ***Victron Skylla battery charger models 24/25, 24/50, 24/75 & 24/100***

This manual contains directions for installing the Skylla battery charger models 24/25, 24/50, 24/75 & 24/100. It describes the functionality and operation of the Skylla battery charger, including its protective devices and other technical features.



This page intentionally left blank.

## CONTENTS



<b>1.</b>	<b>DESCRIPTION</b>	<b>7</b>
1.1.	General	7
1.2.	Skylla charger	7
1.3.	Description	8
<b>2.</b>	<b>PROTECTION</b>	<b>9</b>
2.1.	Short circuit protection	9
2.2.	Temperature protection	9
2.3.	Input protection	9
<b>3.</b>	<b>COMPENSATED CHARGING</b>	<b>11</b>
3.1.	Connection of temperature sensor	11
3.2.	Battery temperatures of up to +10°C	11
3.3.	Battery temperatures between +10°C and +50°C	11
3.4.	High battery temperature	12
<b>4.</b>	<b>INSTALLATION</b>	<b>13</b>
4.1.	Mounting	13
4.2.	Installation requirements	13
4.3.	Connections	13
4.3.1.	Earthing	13
4.3.2.	Mains input	14
4.3.3.	Battery output	14
4.3.4.	Battery voltage alarm	15
4.3.5.	Temperature sensor	15
4.4.	Remote control	15
<b>5.</b>	<b>START UP</b>	<b>17</b>
5.1.	Operating	17
5.2.	“boost-float” cycle	18
5.2.1.	“boost” period	18
5.2.2.	“boost” period	18
5.2.3.	“Boost-float” period	18
<b>6.</b>	<b>CALIBRATION</b>	<b>19</b>
6.1.	Adjusting the charge voltage	19
6.1.1.	Setting the charge voltage.	19
6.1.2.	Setting the “boost” voltage	20
6.1.3.	Setting the “float” voltage	20
6.1.4.	Adjusting charging voltage for use with a diode splitter	20
6.1.5.	Adjusting charging voltage for 12 Volt batteries	21



6.1.6. Adjusting maximum charging current	21
6.2. Maintenance	21
6.3. Jumpers	22
6.4. Potentiometers	22
<b>7. FAULT FINDING</b>	<b>23</b>
7.1. Fault finding	23
<b>8. SPECIFICATIONS</b>	<b>29</b>
8.1. Input	29
8.2. Output	29
8.3. General	30
8.4. Environment	30
8.5. Mechanical	31
8.6. Connections	31
<b>9. DRAWINGS</b>	<b>33</b>
Victron Skylla charger dimensions	34
Victron Skylla charger connections	35
Victron Skylla charger remote control connections	36
Victron Skylla 24/25 connections power PCB	37
Victron Skylla 24/50 and 24/75 connections power PCB	38
Victron Skylla 24/100 connections power PCB	39
Victron Skylla 24/100 115 Volt connections	40



# 1. DESCRIPTION

## 1.1 General

All Victron Skylla 24/25, 24/50, 24/75 and 24/100 battery chargers are subjected to full functional testing before leaving the factory. They are properly packed for secure transportation.

**IP21=**  
protection against materials larger than 12 mm (for example a finger) and protection against vertically descending water-drops (condensation).

The Skylla charger is housed in a IP21 (24/25 and 24/50) or a IP20 (24/75 and 24/100) specification aluminum case designed for wall or floor mounting. The mains input, battery output and alarm output (if used) connections are made through the under side of the housing.

**IP20=**  
protection against solid matter larger than 12 mm (e.g. a finger)

## 1.2 Skylla charger

The Skylla charger is designed for a 24V lead-acid battery system. The maximum charging current and recommended battery capacity can be found in table 1. The standard Skylla charger is suitable for traction batteries. Please consult your local Victron Energie agent for more details.

**Ah =**  
Ampere hours

Skylla type	maximum charging current	recommended battery capacity
24/25	25	100-200 Ah
24/50	50	200-400 Ah
24/75	75	300-600 Ah
24/100	100	500-800 Ah

The Skylla charger is a fully automatic battery charger. It is powered by 230V 50/60 Hz nominal supply main. The input can be converted to 115V. It is designed to be permanently connected to the lead-acid batteries. It is no longer necessary to disconnect the charger during long term storage, for example during winter storage.

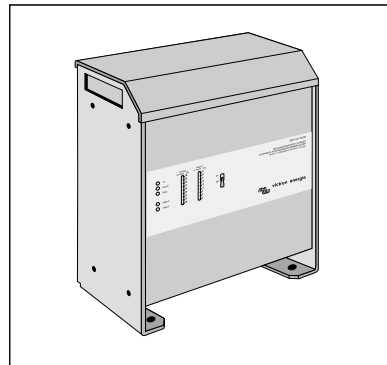

### 1.3 Description

The Skylla charger will charge the battery as soon as the power switch is turned on, provided there is a mains supply. If automatic charge mode is selected (see connection diagram), the battery will be charged with the built in IUoUo characteristic. The float voltage is factory preset to 26.5 V. The boost voltage is factory preset to 28.5 V. The boost and float voltages are user adjustable (see chapter 6).

**Warning: Because of the extremely high voltages permanently present within the Skylla charger, we insist that only a qualified electrician makes all the connections and adjustments within the charger. Make sure the Skylla charger is turned off when connecting, and use an insulated electrician's screwdriver to make all connections and to adjust the voltage and current control.**

## 2. PROTECTION

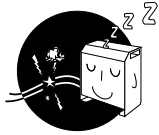

**short circuit current = current supplied when a short-circuit on the output occurs.**

The Skylla charger is inherently safe due to its robust design and internal safety features.

### 2.1 Short circuit protection

The output current is fully short circuit protected. The output current is internally limited under all conditions (see specifications). The battery cables are thus protected in the event of a short circuit.

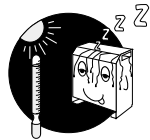

### 2.2 Temperature protection

If the internal temperature of the Skylla charger increases, the output current decreases accordingly. Under extreme conditions (the ventilation holes could be blocked the internal temperature will become too high, and the machine will shut itself down. When the internal temperature is again within limits, the Skylla charger will resume operation.

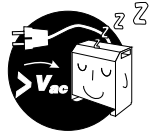

### 2.3 Input protection

The input of the Skylla charger is protected by two slow blow fuses.

Skylla type	input voltage	input fuses
24/25	230 Volt	2 x 6 Ampere
	115 Volt	2 x 10 Ampere
24/50	230 Volt	2 x 10 Ampere
	115 Volt	2 x 15 Ampere
24/75	230 Volt	2 x 15 Ampere
	115 Volt	2 x 20 Ampere
24/100	230 Volt	32 Ampere automatic
	115 Volt	64 Ampere automatic

This page intentionally left blank.

## **3. COMPENSATED CHARGING**

The Skylla has a temperature compensation facility which adjusts the charger voltage to the battery temperature.

In order to use this facility, a temperature sensor (V.T.S.) must be fitted to the battery. This is because a higher charging voltage can be used with a cold battery than with a warm battery. The reference charging voltage is 28.5 V at a battery temperature of 20°C (see illustration 1).

### **3.1 Connection of temperature sensor**

In order to connect the temperature sensor, jumper S101 must first be switched to pins 2 and 3 (see Drawings section, drawing no. SK02006E, page 35). The yellow temperature sensor LED will light up if the temperature sensor is connected. (for information on jumpers, see section 4.6, “Jumpers”).

### **3.2 Battery temperatures of up to +10°C**

At temperatures of up to +10°C, the charger supplies a maximum charging voltage of 29.1V. This output voltage is limited because at higher voltages problems might occur in the external equipment (see illustration 1, section “A”).

### **3.3 Battery temperatures between +10°C and +50°C**

In this temperature range, the output voltage is dependent on battery temperature (as measured by the sensor). As the temperature increases, the output voltage of the charger decreases by 60 mV/°C (5mV/°C per cell). (See illustration 1, section “B”).



### 3.4 High battery temperature

At battery temperatures of +50°C and above, the charging voltage drops sharply. At values of 55°C and above, the charger operates as a rectifier with an output voltage of 24 V (see illustrations 1, sections “C” and “D”).

The plastic bag containing connection materials includes instructions showing where the temperature sensor must be fitted. It is also necessary to change jumper S101 on the control PCB (see section “Drawings”, drawing number SK02006E, page 35)

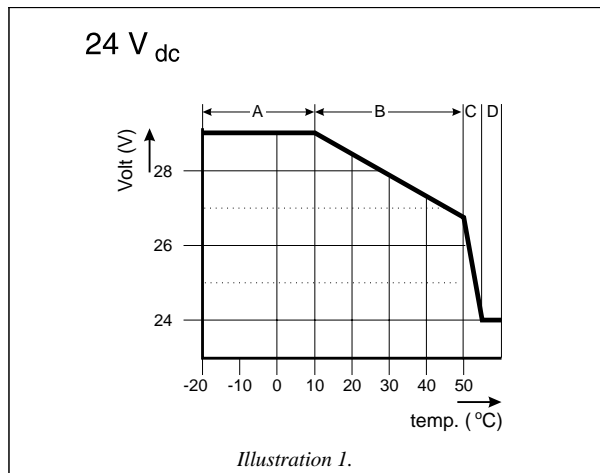

Illustration 1.



## 4. INSTALLATION

### 4.1 Mounting

Wall or floor mount the Skylla charger in a dry, well ventilated area. Excessively high ambient temperatures may adversely affect the output current and the lifetime of the Skylla charger. Best results are obtained in such conditions if the Skylla charger is wall mounted. For secure placement, the Skylla is supplied with mounting holes both in the rear and in the underside, see drawing sk02018e on page 34.

Make sure the front panel can be reached after installation. The Skylla charger and the battery's should be placed close together to keep the battery cables as short as possible, ensuring optimal loading.

### 4.2 Installation requirements

The Victron Skylla charger should be installed with the help of the following equipment:

- a three core mains cable for connection core cross section should be  $2.5\text{mm}^2$  (24/25 and 24/50) or  $6\text{mm}^2$  (24/75 and 24/100)
- two battery cables (max. length 6 meters, with clamps)
- a screwdriver (no. 3) to remove the front panel and to connect the battery cables

### 4.3 Connections

By unscrewing the four front screws the front panel can be removed. This way the Skylla internals are exposed for connection. All connections are located at the bottom of the charger. Cables can be fed through the holes in the bottom of the casing.

**Victron battery chargers are designed to charge batteries; the charger always expects the load of a battery and it is not a power supply. Connect the battery before switching the charger on and switch the charger off before the battery is disconnected.**



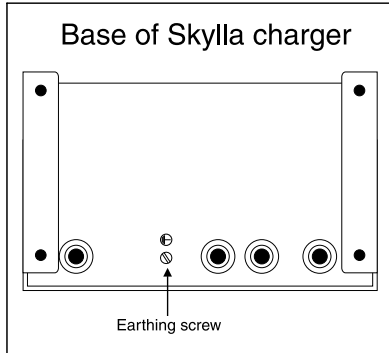

Illustration 2a. Position of earthing screw on the Skylla 24/25.

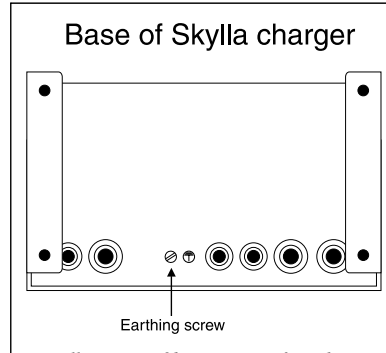

Illustration 2b. Position of earthing screw on the Skylla 24/50.

#### 4.3.1 Earthing

The Skylla charger is not a double insulated charger. The PE terminal must be connected to a true earth under all conditions. On a boat, the earth terminal on the under side of the housing must be connected to the ground plate or the hull. The shore connection must be earthed to the PE terminal on the mains input connection block. For mobile applications (car, caravan et cetera) earth terminal must be connected to the metal chassis.

#### 4.3.2 Mains input

Use a three core approved cable to connect the Skylla charger to the mains. Remember that the PE terminal must **always** be earthed.

wire	description	color
L1	Phase	brown or black
N	Neutral	blue
PE	Earth	green/yellow

**Earth =**  
 (PE): yellow and green striped colour wire  
**Phase =**  
 (L): brown or black colour wire  
**Neutral =**  
 (N): blue colour wire

#### 4.3.3 Battery output

It is important that the connection between the Skylla charger and the battery is made in such a way that power loss is minimized. The cables must be as short and as thick as possible to reduce resistance. We recommend using cable shoes as supplied. We recommend the following minimum copper cross section for these battery cables:



Skylla type	Length	cross section
24/25	0 - 1.5 meters	6 mm <sup>2</sup>
	1.5 - 6 meters	10 mm <sup>2</sup>
24/50	0 - 1.5 meters	10 mm <sup>2</sup>
	1.5 - 6 meters	16 mm <sup>2</sup>
24/75	0 - 1.5 meters	16 mm <sup>2</sup>
	1.5 - 6 meters	25 mm <sup>2</sup>
24/100	0 - 1.5 meters	35 mm <sup>2</sup>
	1.5 - 6 meters	50 mm <sup>2</sup>

Cable lengths in excess of 6 meters are not recommended.

#### **4.3.4 Battery voltage alarm**

The Skylla charger has a potential free contact which is closed if the battery voltage is out of range for more than 1 minute. The contact is activated if the battery voltage is higher than 33.6 V or lower than 23.8 V. This potential free contact can be used to activate a remote alarm. Consult your dealer for more details about the possible applications of this alarm. The maximum current through this contact is detailed in the specification.

#### **4.3.5 Temperature sensor**

The Skylla chargers can be equipped with a temperature sensor (T.S.) connected to the battery. The sensor measures the battery temperature continuously, allowing the charge voltage to adjust to the temperature of the battery.

To correctly connect the T.S. jumper S101 must be move from pins 1 and 2 to pins 2 and 3, illustration 7. For further information on jumpers see paragraph 6.4. If the positive and negative are connected incorrectly the yellow LED will not light up.

## 4.4 Remote control

The Skylla charger can be equipped with a remote control unit, the Skylla Control (SKC, see illustration). The SKfront has LEDs displaying “charger on”, “boost” and “float” and a potentiometer to decrease the maximum charge current. The connections for the Skylla are made through a six wire cable, see drawing number SK02007E, page 36.

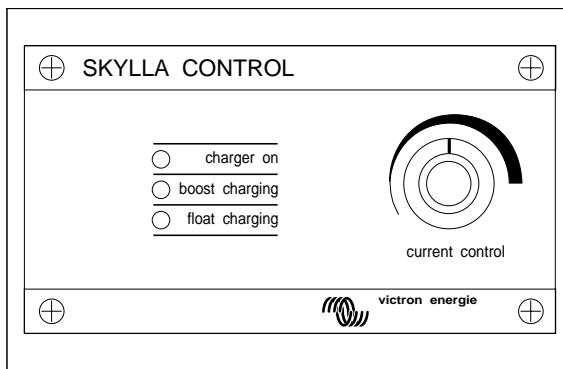

## 5. START UP



### 5.1 Operating

On the front panel of the Skylla charger a power switch and the following indicators can be found:

**LED =**  
**Light Emitting**  
**Diode**

Indicator name	description
on	Indicates whether the Skylla charger is turned on
boost	Indicates charger is operating in boost mode
float	Indicates charger is operating in float mode
output	battery voltage to high
output	battery voltage to low
output voltage (V)	Indicates charger output voltage
output current (A)	Indicates charger output current

If the mains are connected and the switch “charger on” is set in the “on” position, the LEDs “on” and “output ⊕” will light

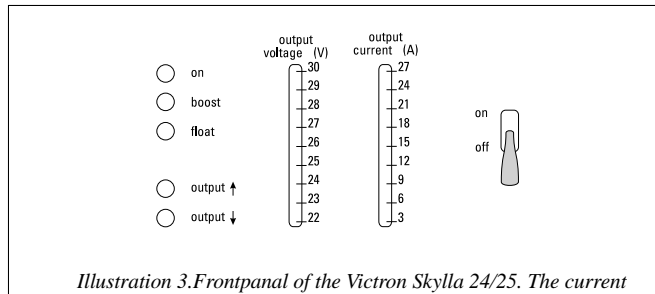

*Illustration 3. Front panel of the Victron Skylla 24/25. The current indicator is slightly different for the 50, 75 and 100 Ampere models.*

up immediately. After about 10 seconds the charger will commence charging and the LEDs “output current” and possible the LEDs “output voltage” will light up.

The output voltage will rise slowly and the LED “output ⊕” will turn off. The output voltage will increase to 28.5 Volt<sub>dc</sub>, at which point the LED “boost” will light up.

## 5.2 “boost-float” cycle

### 5.2.1 “boost” period

During the first part of the “boost” period, the “boost” LED is turned off and the batteries are charged with the maximum charging current. The battery voltage will increase until it reaches 28.5 volts, at which point the “boost” LED will light up. This marks the start of the second part of the boost period, which will last for 4 hours. During this period the charging current will decrease. After 4 hours the batteries will have been charged to 80% their maximum capacity. After the “boost” period is over, the “boost” LED will be turned off, the “float” LED will light up and the “float” period will start.

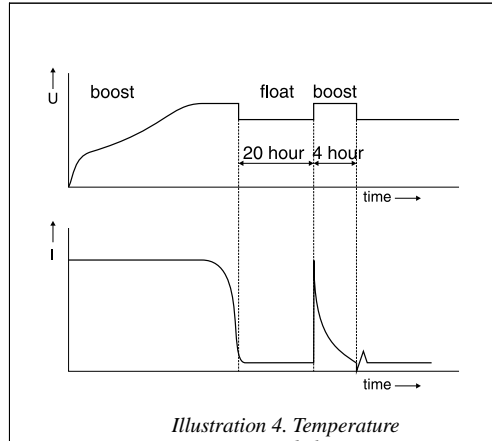

Illustration 4. Temperature compensated charging.

### 5.2.2 “Float” period

During the “float” period the “float” LED will light up and the output voltage will be 26.5 Volt<sub>dc</sub>. If the output voltage decreases to below 25 Volts (the “output ⊕” will light up), the “boost” period will start. This might occur if the load is too large or if the charger is temporarily turned off.



## 6. CALIBRATION

### 6.1 Adjusting the charge voltage

The float voltage is factory preset to 26.5 V. The boost voltage is factory preset to 28.5 V. The boost and float voltages are user adjustable. These values are recommended by almost all lead-acid battery manufacturers. The current and voltage settings do not have to be periodically checked.

**Warning: Because of the extremely high voltages permanently present within the Skylla charger, we insist that only a qualified electrician makes any adjustments within the charger. Make sure the Skylla charger is turned off when connecting, and use an insulated electrician's screwdriver to make all connections and to adjust the voltage and current control.**

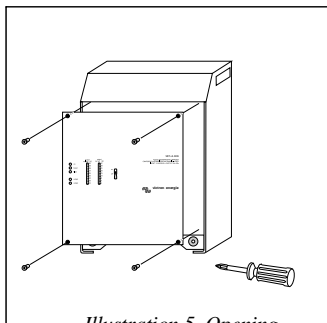

Illustration 5. Opening the cabinet.

If you want to adjust the charge voltage, remove the front panel of the Skylla charger. Unscrew the four countersunk screws with a Phillips screwdriver, and pull the panel free.

#### 6.1.1 Setting the charge voltage.

The Skylla charger uses two different charging voltages, the “boost” charging voltage and the “float” charging voltage. These voltages can be set independently, with potentiometer R64 and R63 respectively.



### 6.1.2 Setting the “boost” voltage

While adjusting the charger voltages, the batteries should be well charged, the charging current should not exceed 5 Ampere. While adjusting the “boost” voltage, the charger should be in “boost” mode (the “boost” LED should be on). Connect a digital voltage meter, with a 0.1 Volt resolution, to the output. Adjust R64 until the required output voltage is reached.

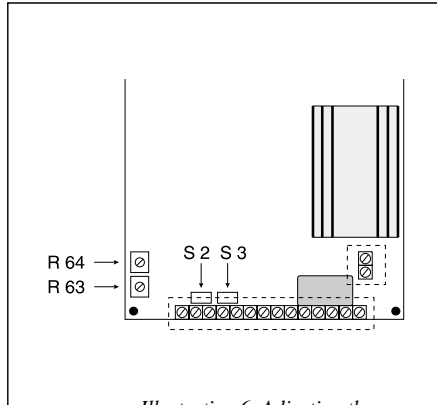

Illustration 6. Adjusting the “boost” (R64) and “float” (R63)

### 6.1.3 Setting the “float” voltage

It is possible, for test purposes, to speed up the “boost” period to 10 seconds (normally 4 hours) by removing jumper S2 (illustration 6). The jumper should be replaced as soon as the “float” LED lights up. The “float” charging voltage can now be set by adjusting R63. Normal operation is resumed by turning the charger off and on.

### 6.1.4 Adjusting charging voltage for use with a diode splitter

A diode splitter can be connected to the Skylla charger. The output voltage must be increased to compensate for the voltage drop over the diode splitter. By removing jumper S1 (see illustration 7) the output voltages automatically increases with 0.6 Volts. The “float” and “boost” voltages can be set separately by adjusting R63 and R64. The output voltage should then be measured after passing through the diode splitter. The voltages should be 28.5 Volt (“boost”) and 26.5 Volt (“float”).

**Warning: Because of the extremely high voltages permanently present within the Skylla charger, we insist that only a qualified electrician makes adjustments in the Skylla charger. Make sure the Skylla charger is turned off when connecting, and use an insulated electrician’s screwdriver to make all connections and to adjust the voltage or current control.**

### 6.1.5 Adjusting charging voltage for 12 Volt batteries

For use with 12 Volt batteries the jumpers S7 and S8 should be placed. The “boost” and “float” voltages will then be set automatically to, respectively, 14.25 Volt and 13.5 Volt. No adjustment is required.

### 6.1.6 Adjusting maximum charging current

The maximum charging current is factory set to:

Skylla	maximum charging current
24/25	25 Ampere
24/50	50 Ampere
24/75	75 Ampere
24/100	100 Ampere

The maximum charge current can be set by adjusting R16, see illustration 7. While setting the maximum charging current, the output voltage should always remain 24 Volts. The maximum charging current should never exceed the factory set value for that specific charger type.

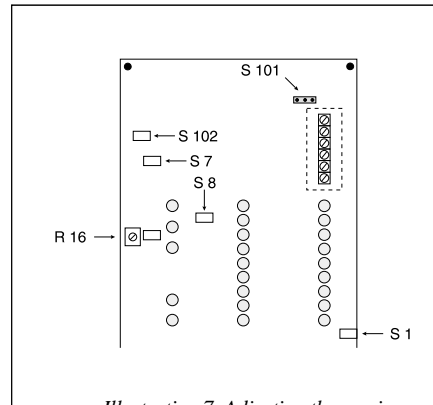

Illustration 7. Adjusting the maximum charge current.

## 6.2 Maintenance

The Skylla charger requires no special maintenance. It is however recommended that the electrical connections be checked twice a year, and that the charger is kept dry, clean and dust free. If any problems arise, use the fault finding procedure in this manual to trace the fault.

### 6.3 Factory setting

The factory settings for the Skylla chargers are:

jumper or potentiometer	setting	description
S1	placed	normal (no diode splitter)
S2	placed	normal (no float test)
S3	removed	normal battery
S7	removed	24V battery
S8	removed	24V battery
S101	1&2	no temperature sensor
S102	placed	normal battery
R16	25/50/75/100A (depending on model)	current limit adjustment
R63	26.5V	float voltage adjustment
R64	28.5V	boost voltage adjustment

### 6.4 Jumpers

Jumpers are small removable connectors situated on the PCB. By placing and removing the jumpers various features can be enabled or disabled.

Illustration 8 shows how to set the jumpers.

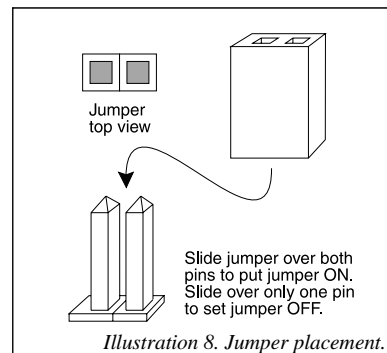

### 6.5 Potentiometers

Potentiometers are adjustable resistors. Turning the screw increases or reduces the values associated within the potentiometer.

These values may concern matters such as voltage, frequency or switch on sensitivity. The screw must be turned by means of a screwdriver (No. 0) and sealed with nail polish. See also illustration 9.

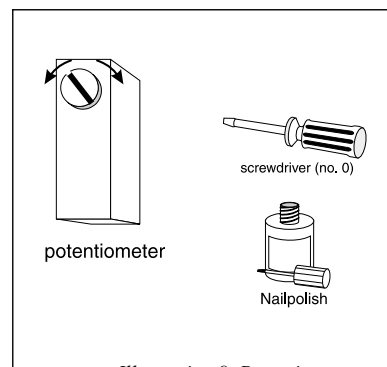



## **7. FAULT FINDING**

### **7.1 Fault finding**

The following 3 diagrams are included to assist you in finding the fault. Experience has shown that most faults can be solved with this procedure. Before checking the Skylla charger, remove all loads from the charger, and connect the unit to mains supply.

The following conditions are covered by the diagrams:

- battery charger does not work
- batteries are being overcharged
- batteries are not being fully charged



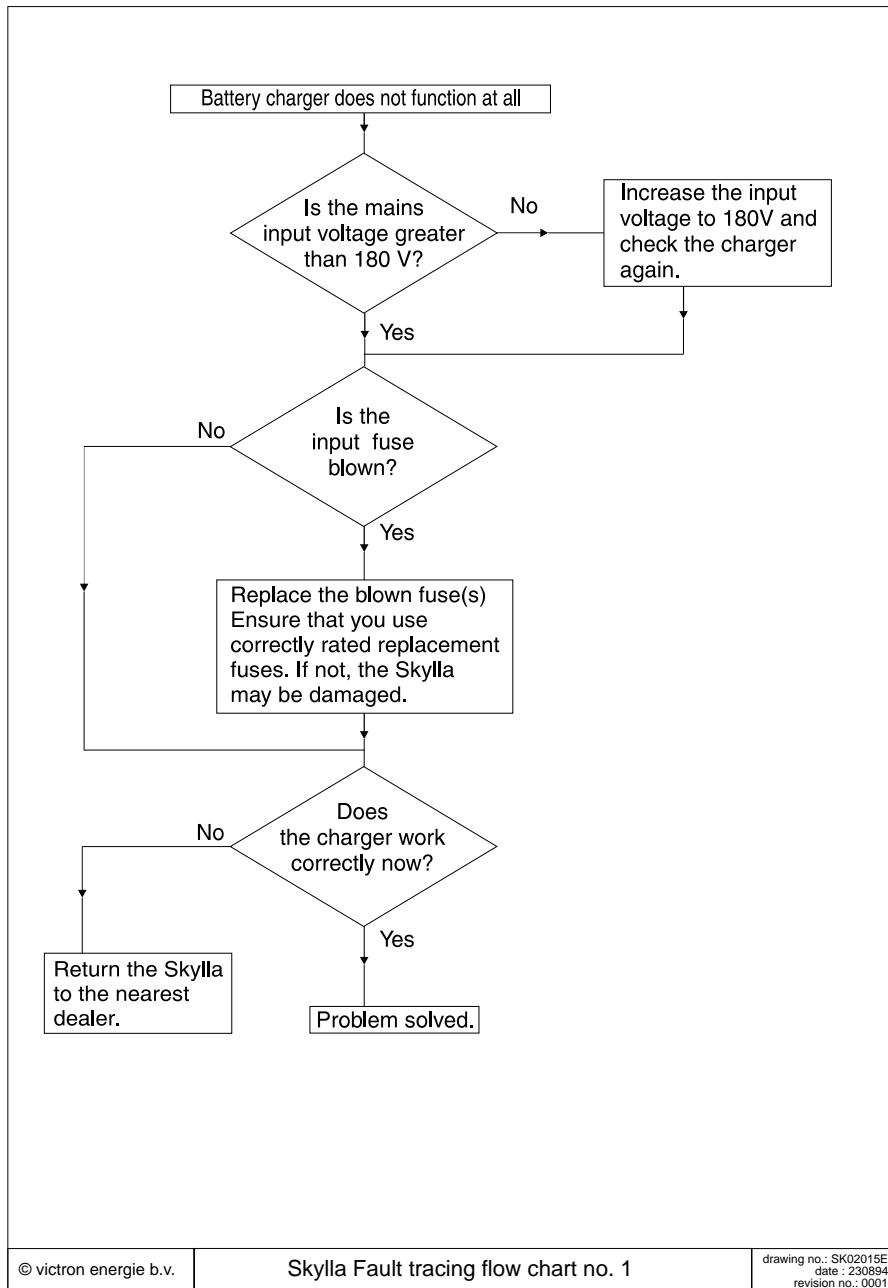

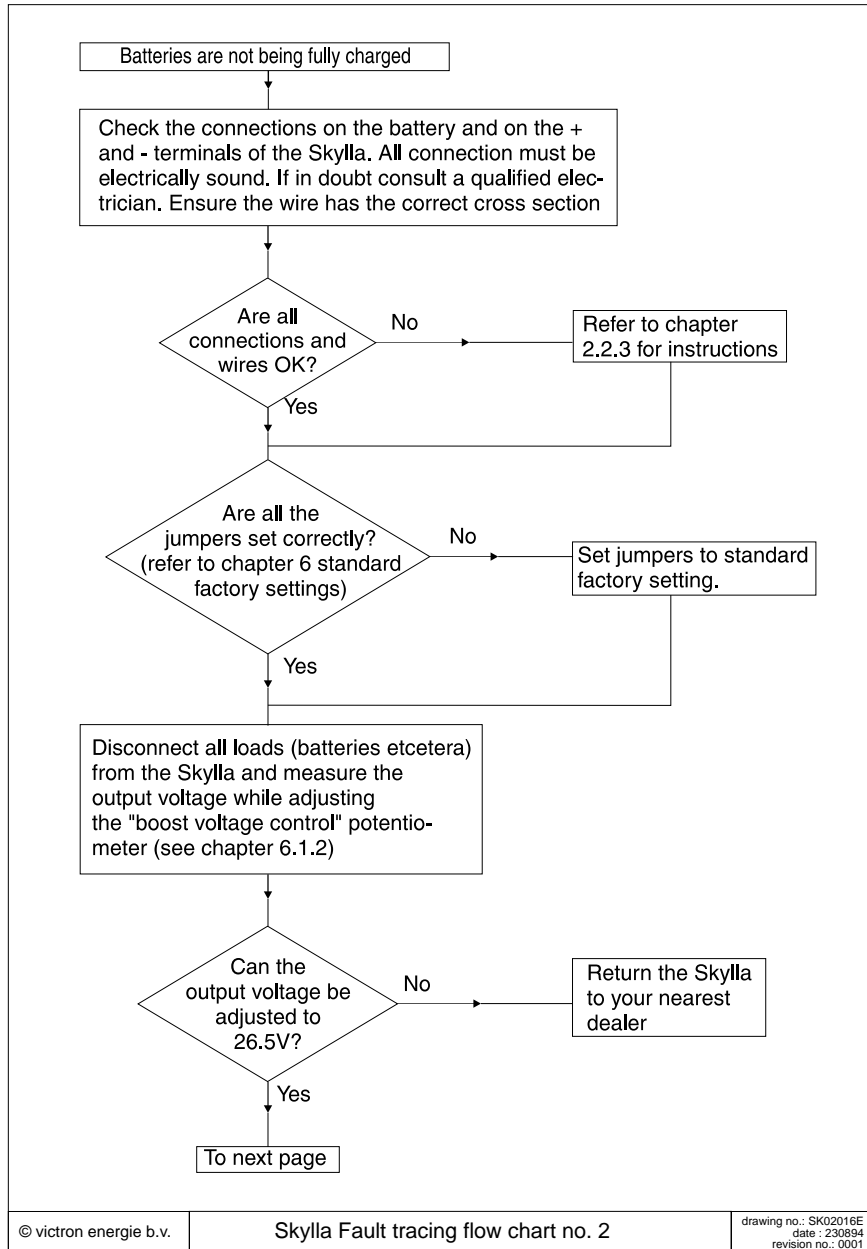

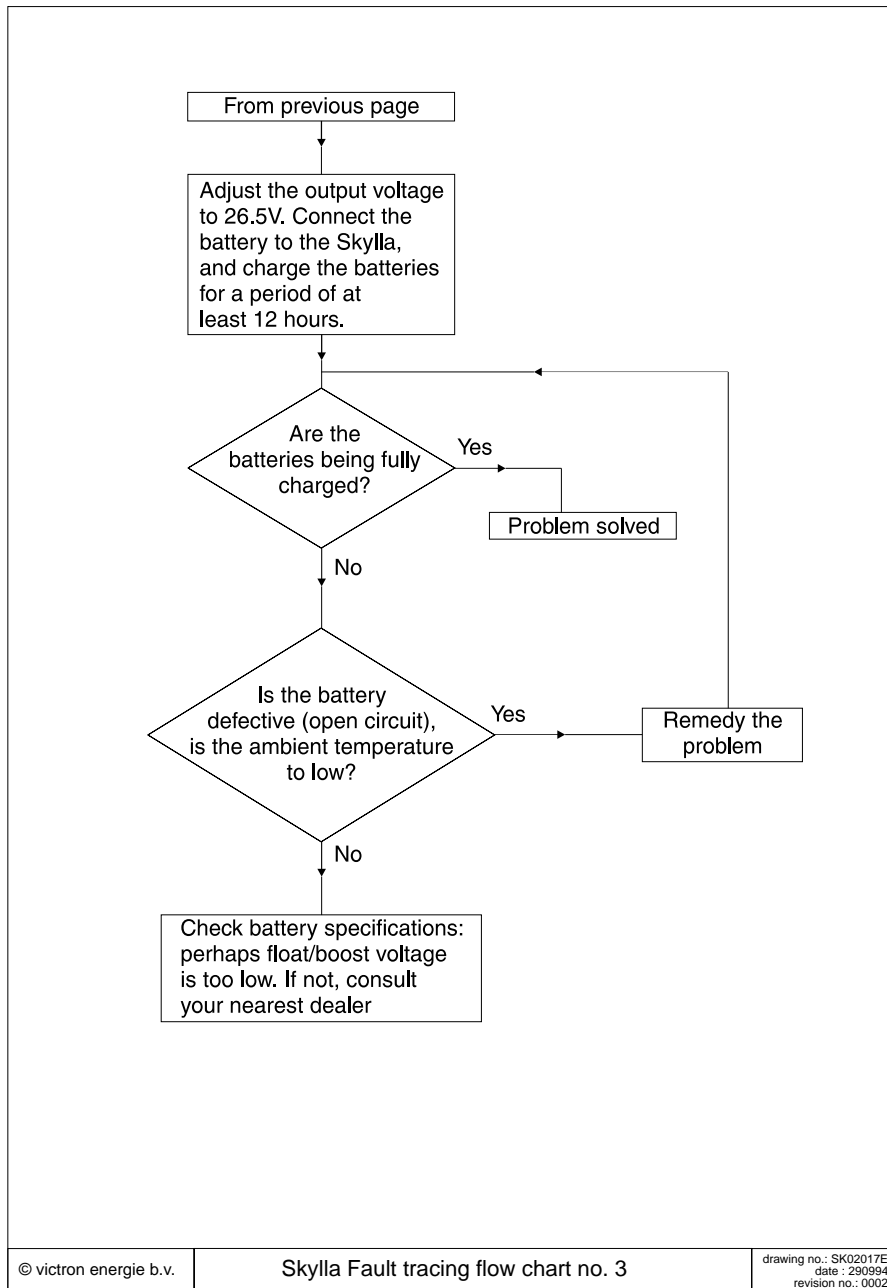

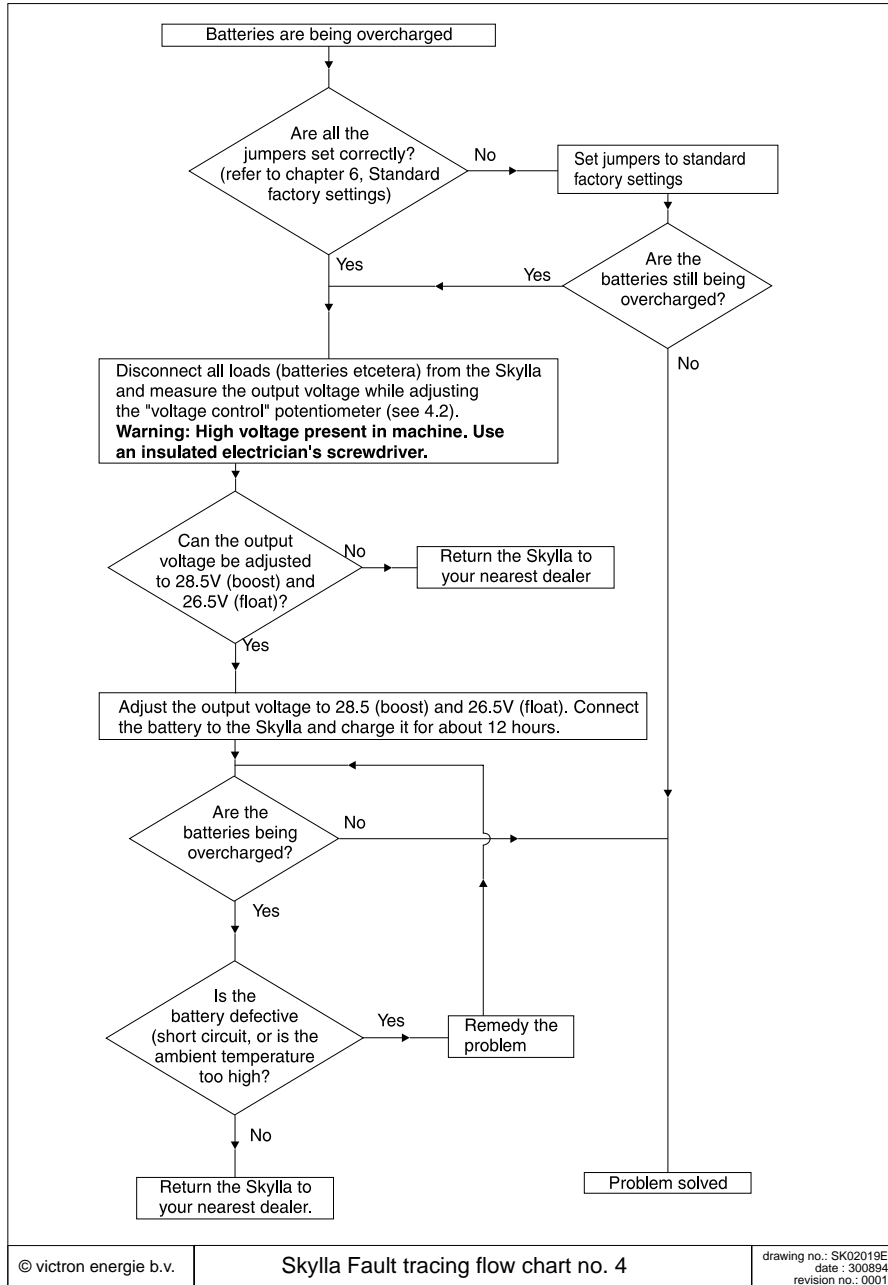

This page intentionally left blank.

## 8. Specifications



### 8.1 Input

Nominal input voltage:	230 V
Input voltage protection:	Unit shuts down if input voltage drops below 160 V. The unit will resume operation if the input voltage rises above 180 V.
Frequency range:	47 - 63Hz
Input fuse (230 V):	
Skylla 24/25	2 x 6A slow 6.3 x 32 mm
Skylla 24/50	2 x 10A slow 6.3 x 32 mm
Skylla 24/75	2 x 15A slow 6.3 x 32 mm
Skylla 24/100	32A automatic switch
Input fuse (115 V):	
Skylla 24/25	2 x 10A slow 6.3 x 32 mm
Skylla 24/50	2 x 15A slow 6.3 x 32 mm
Skylla 24/75	2 x 20A slow 6.3 x 32 mm
Skylla 24/100	64A automatic switch
Power factor:	0.7 at full load 0.64 at half load
Input current:	
Skylla 24/25	6A at 230V input on full load
Skylla 24/50	11A at 230V input on full load
Skylla 24/75	19A at 230V input on full load
Skylla 24/100	26A at 230V input on full load



### 8.2 Output

Nominal charging voltage:	24V
High charging voltage (boost):	28.5V
High charging voltage range:	25.5 -29.0 V
Low charging voltage (float):	26,5V
Low charging voltage range:	24 - 28.5V
Charging characteristic:	IUOUO in accordance with DIN 41772
Voltage stability:	1%

All specifications are subject to change without notice



Voltage compensation	
Diode splitter	+ 0.6V through jumper
traction battery	+ 2.0V through jumper
Output voltage alarm	5A potential free contact
Output current:	
Skylla 24/25	25A
Skylla 24/50	50A
Skylla 24/75	75A
Skylla 24/100	100A
Output current ripple:	70% rms at full load
Output current stability:	+/- 5 %
Short circuit protection:	Continuous short circuit proof



### 8.3 General:

Radio interference suppression:	EN55014
Electromagnetic compatibility:	IE801-2 class 3 IE801-3 class 2 IE801-4 class 2 for the output IE801-4 class 3 for the input IE801-5 class 3
Safety:	IE335-2-29

### 8.4 Environment:

Temperature range:	-10 to 50°C. The charge current decreases if the temperature rises above 40°C
Cooling:	Natural cooling



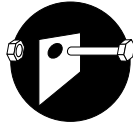

## 8.5 Mechanical:

Noiselevel:	< 40 dB(A)
Case:	
Skylla 24/25	Aluminum IP21
Skylla 24/50	Aluminum IP21
Skylla 24/75	Aluminum IP20
Skylla 24/100	Aluminum IP20
Color:	Blue (RAL5012) epoxy
Dimensions (h x b x d):	
Skylla 24/25	350 x 250 x 216 mm
Skylla 24/50	420 x 300 x 240 mm
Skylla 24/75	490 x 350 x 280 mm
Skylla 24/100	490 x 350 x 280 mm
Weight:	
Skylla 24/25	16 kg
Skylla 24/50	29 kg
Skylla 24/75	33 kg
Skylla 24/100	42 kg

## 8.6 Connections

Output 24 V <sub>DC</sub> :	
Skylla 24/25	Two pole connector block
Skylla 24/50	M8 bolts
Skylla 24/75	M8 bolts
Skylla 24/100	M8 bolts
Input 230 V <sub>AC</sub> plus earth:	3 pole connector block plus extra earth terminal on housing

This page intentionally left blank.

## **9. Drawings**

---

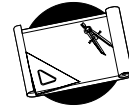

<b>Victron Skylla charger dimensions</b>	<b>34</b>
<b>Victron Skylla charger connections</b>	<b>35</b>
<b>Victron Skylla charger remote control connections</b>	<b>36</b>
<b>Victron Skylla 24/25 connections power print</b>	<b>37</b>
<b>Victron Skylla 24/50 and 24/75 connections power print</b>	<b>38</b>
<b>Victron Skylla 24/100 connections power print</b>	<b>39</b>
<b>Victron Skylla 24/100 115 Volt connections</b>	<b>40</b>



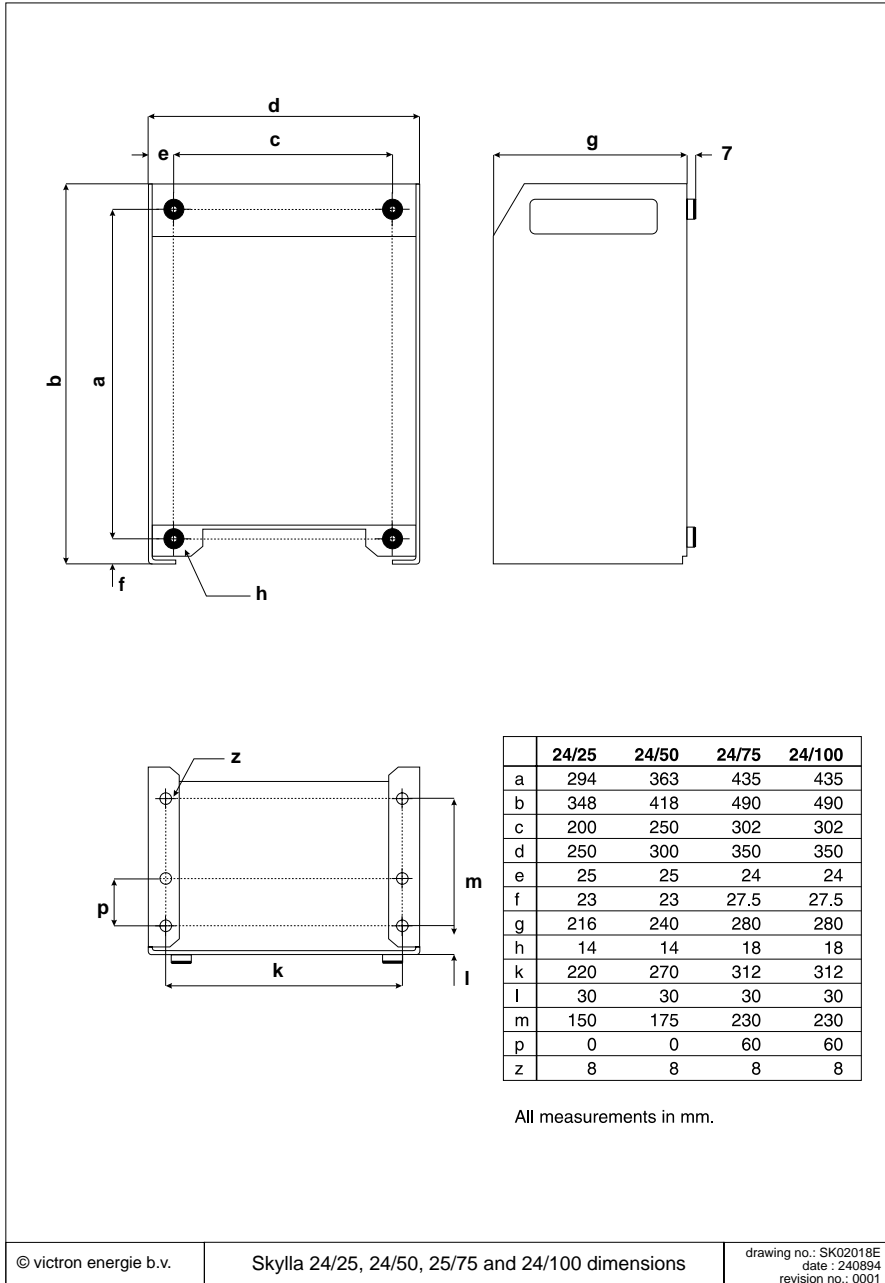

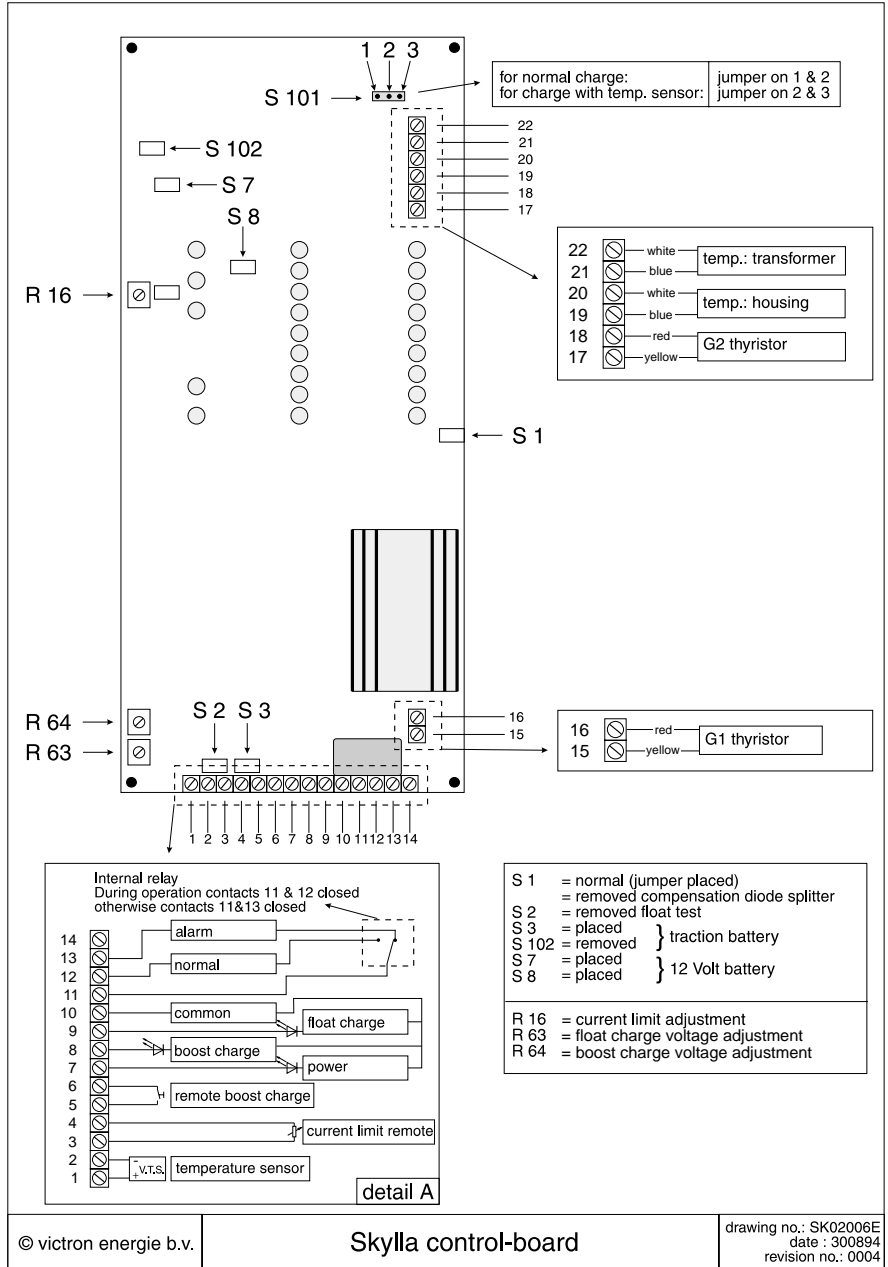

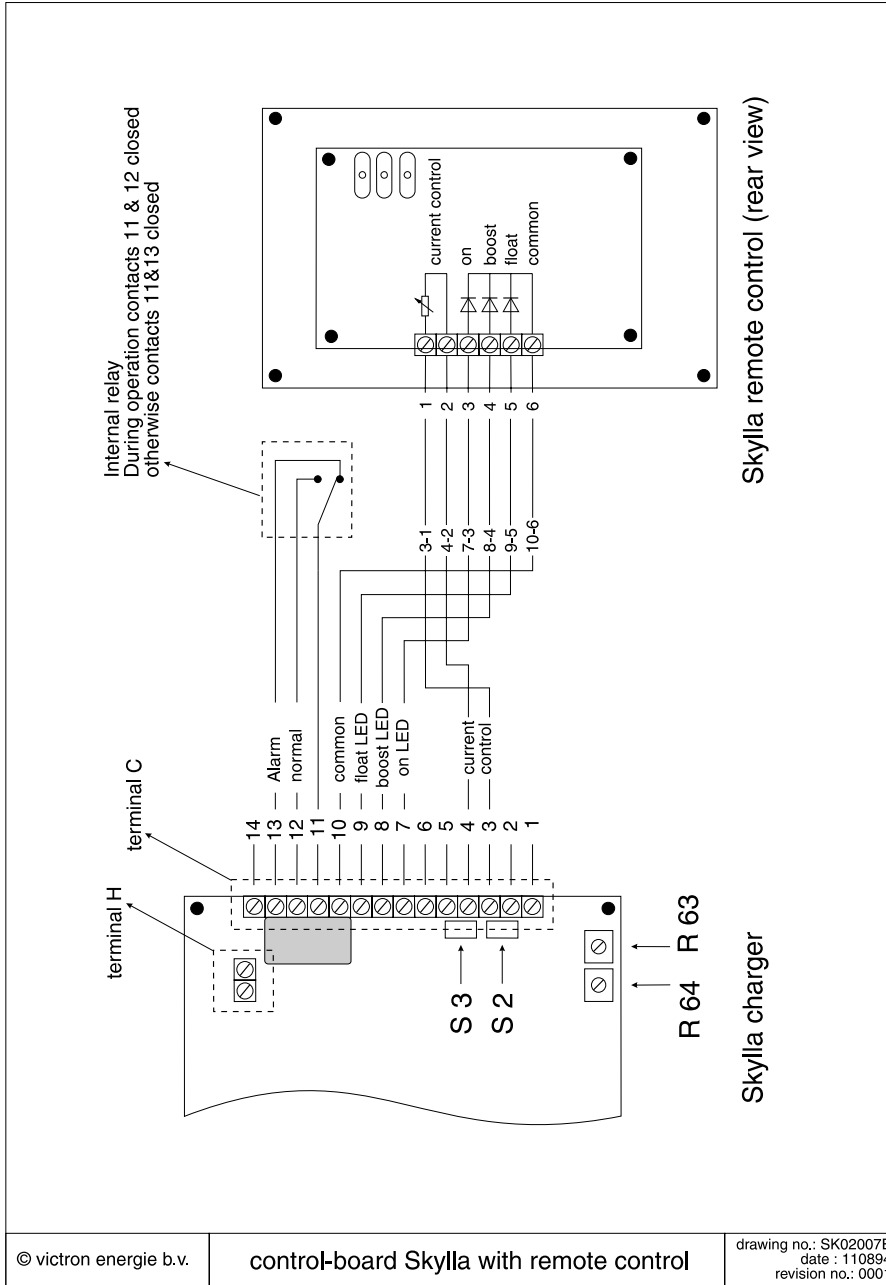

### 115 Volt Connections Changes to the wiring must be made by the user.

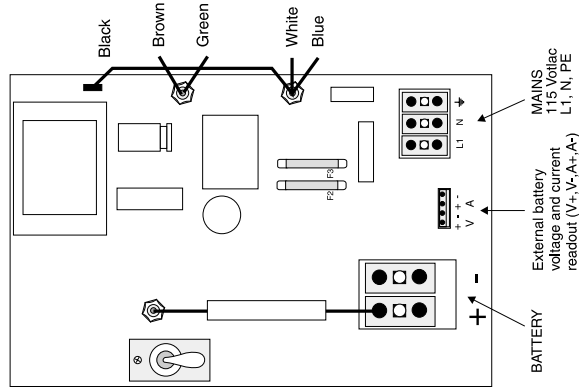

The value of F2 and F3 must be doubled.  
 The black wire must be placed by the user.

### 230 Volt Connections This is the factory setup.

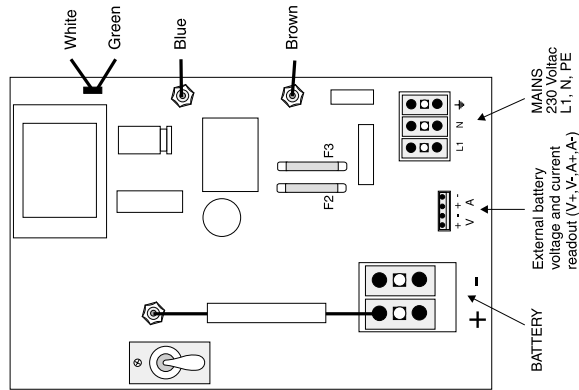

See the manual for the value of F2 and F3.

© victron energie b.v.

Skylia 24/25 with ringcoil mains connection

drawing no.: SK05003E  
 date : 300894  
 revision no.: 0004

## 110 Volt connections

Changes to the wiring must be made by the user.

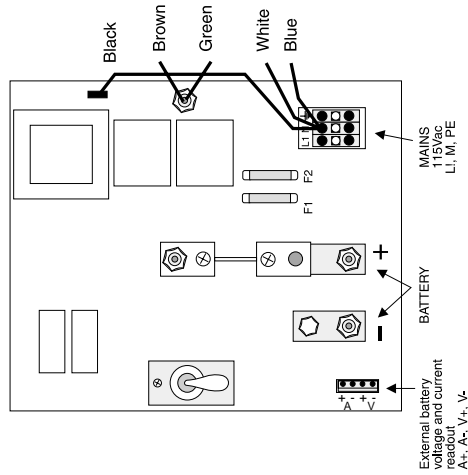

The value of F1 and F2 must be doubled.  
 The black wire must be placed by the user.

## 230 Volt connections

This is the factory setup.

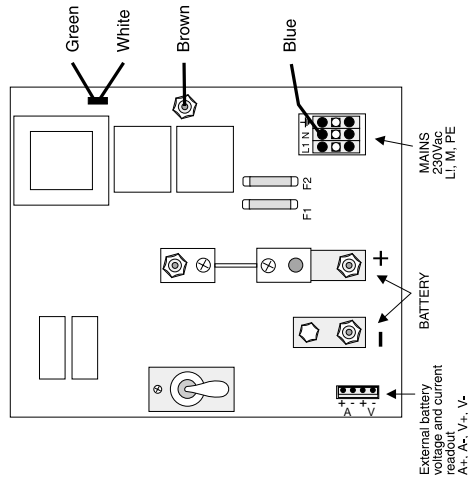

See manual for the value of F1 and F2.

© victron energie b.v.

Skylla 24/50 and 24/75 with ringcoil mains connection

drawing no.: SK03002E  
 date : 300894  
 revision no.: 0003

